

Installation Guidelines Type M

The subgrade has to be compacted to an EV₂ > 45 MN/m², if the concrete base has an overlap of > 50 cm from channels end. Otherwise, it has to be compacted to an EV₂ of > 180 MN/m², or it must be ensured that in case of heavy trucks circulation an overlap of > 50cm from channels end is guaranteed

The dimensioning of the lateral concrete surrounding (x) must be adapted to local site conditions and equals at least 20 cm. In cases where the connection between subgrade and lateral concrete surrounding of the channel is avoided by for example by expansion joints, then dowel bars made of Ø8 mm reinforced steel have to be installed every 30 cm.

Installation Guidelines Type I

The planum is to perform settlement-free so that the expected loads can be derived without damaging the components. For changing substrates or substrates with a lower degree of compaction, an additional foundation must be designed.

Installation Guidelines Type M and Type I

The concrete grades indicated are minimum values. Requirements related to the location of installation, such as resistance to freeze-thaw with de-icing salts, must be taken into account by choosing the appropriate concrete grade in accordance with local restrictions respectively.

With complete concrete surrounded channels system, BIRCO recommends a fully sealing of the channel joints, so as to prevent damage through freeze - thaw conditions (see jointing information!)

It must be ensured that installation is performed expertly, taking into account concrete technology aspects.

All adjoining pavement surfaces must run permanently at a level of approximately 3 to 5 mm higher than the upper edge of the channel. In order to achieve this, we recommend laying the first two to three rows of block paving or paving slabs in a mortar bed. Because there is no concrete encasing, the surfacing can run right up to the channel. In the case of block paving or paving slabs being used as the adjoining surfacing, a durable sealing joint of some 10 mm must be established between the channel and the surfacing. The joints between the first two to three rows of the block paving or paving slabs must be sealed durably in a tight and impermeable manner. It must be ensured that horizontal forces, which may result from the expansion or shifting of the pavement, have no impact on the two to three rows of pavement set in the mortar bed.

Expansion joints in the construction parts adjoining the channel must be planned on the basis of engineering considerations. BIRCO recommends arranging expansion joints parallel to the channel, at a distance of approximately 1m - 2m from the channel line. Expansion joints running transverse to the channel line must be arranged so that they run through a channel joint. We recommend arranging them every 8 to 12 metres (in accordance with DIN 18318, valid edition). The expansion joints (e.g. PE foam sheets) must cover the total cross-sectional area of the channel, as well as the full area of the concrete base and the lateral concrete encasing.

[*] Jointing Information

You will find detailed jointing information under www.birco.de

Bolt Connection Information:

For screw fastening of the gratings, torque moments are to be set at M8 = 25 Nm, M12 = 60 Nm, M16 = 100 Nm. The bolts must be re-tightened at regular intervals.

Additional regulations and guidelines

Local particularities have to be examined and taken into account by the planner. Installation must comply with the latest international/local regulations and guidelines . + The correct load class in accordance with DIN EN 1433 "Drainage channels for vehicular and pedestrian areas" has to be respected.

[+] Exception D 400: not for installation across the roadway in highway and expressways

Channel cross section

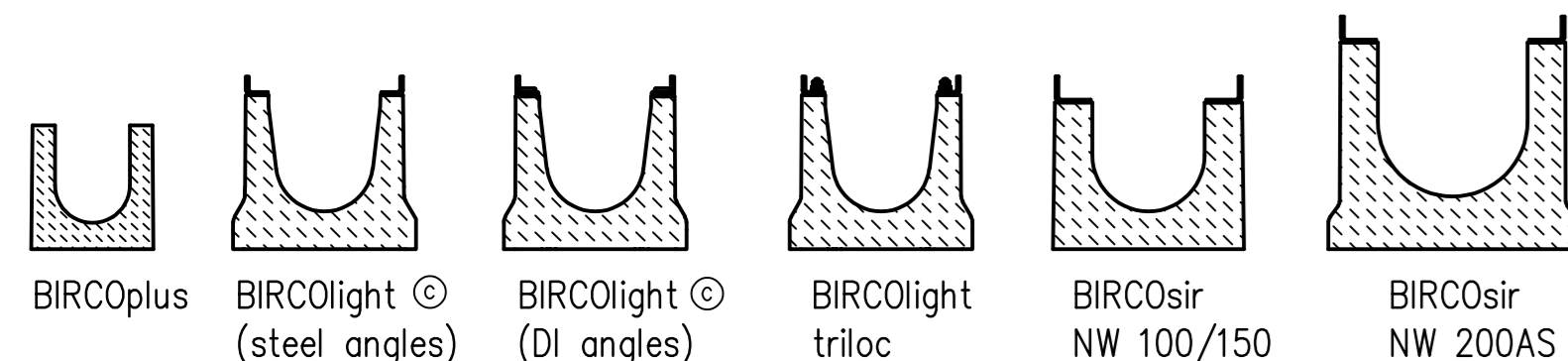

Installation instructions Type M

BIRCOplus NW 100, Type M – load class A15 – C250

BIRCOlight NW 100 / 150 / 200 Type M – load class A15 – C250
BIRCOlight NW 100 / 150 / 200 triloc, Type M – load class A15 – C250

BIRCOsir NW 100/150/200AS, Type M – load class A15 – E600 [+]*

* For heavy-duty areas see example below

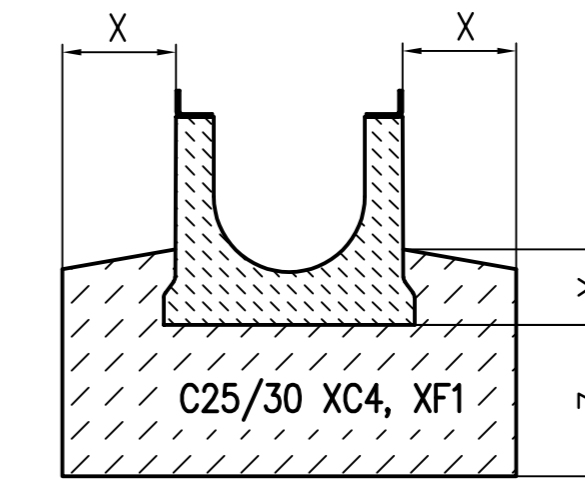
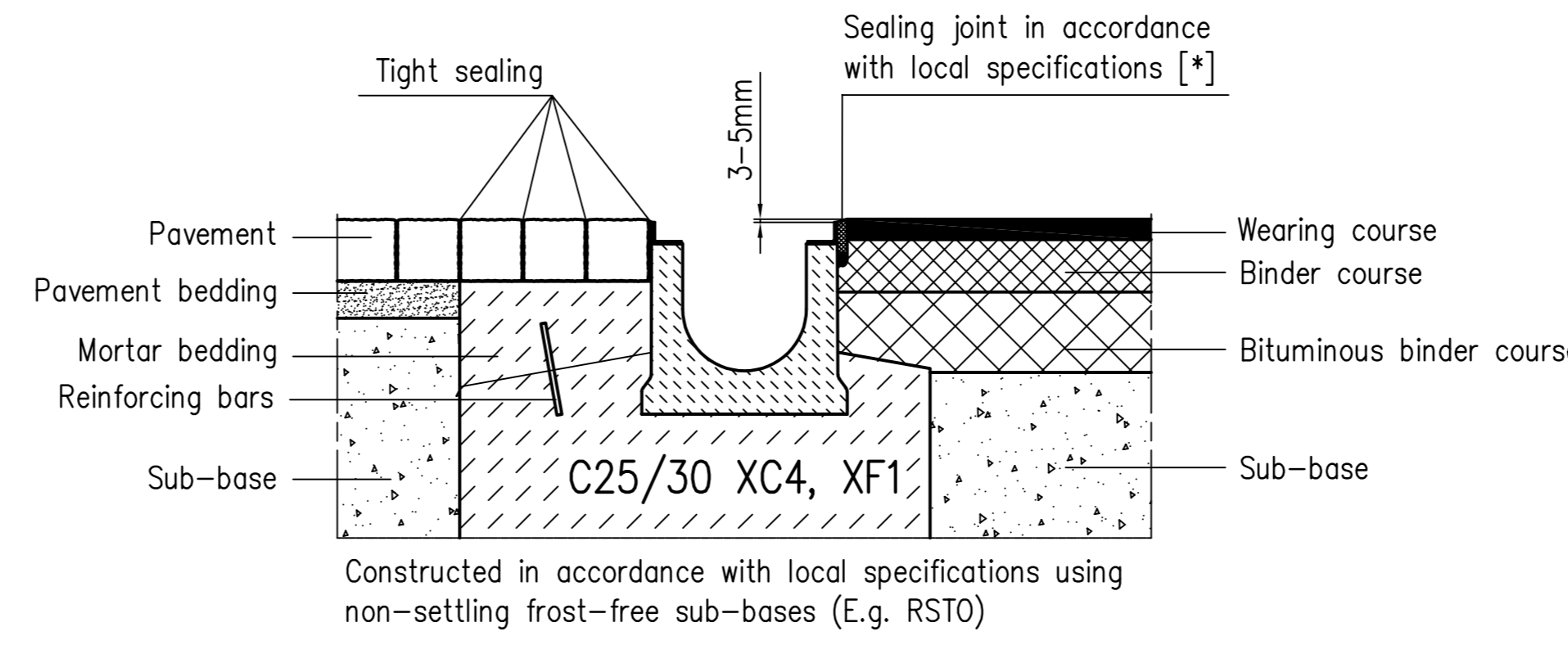

Presentation with BIRCOsir (s. channel cross section)

BIRCOlight NW 100 / 150, Type M – load class D400* – E600*
BIRCOlight NW 100 / 150 triloc, Type M – load class D400* – E600*
 © **BIRCOlight 200 / 200 triloc, Type M** – load class D400*

* suitable for a punctual overrun D 400 / E 600

expended installation instructions for heavy-duty areas subjected to frequent use logistics centers, Transport hubs, maneuvering areas and aircraft pavements

BIRCOsir NW 100 / 150 / 200AS, Type M – load class D400 – F900 [+]

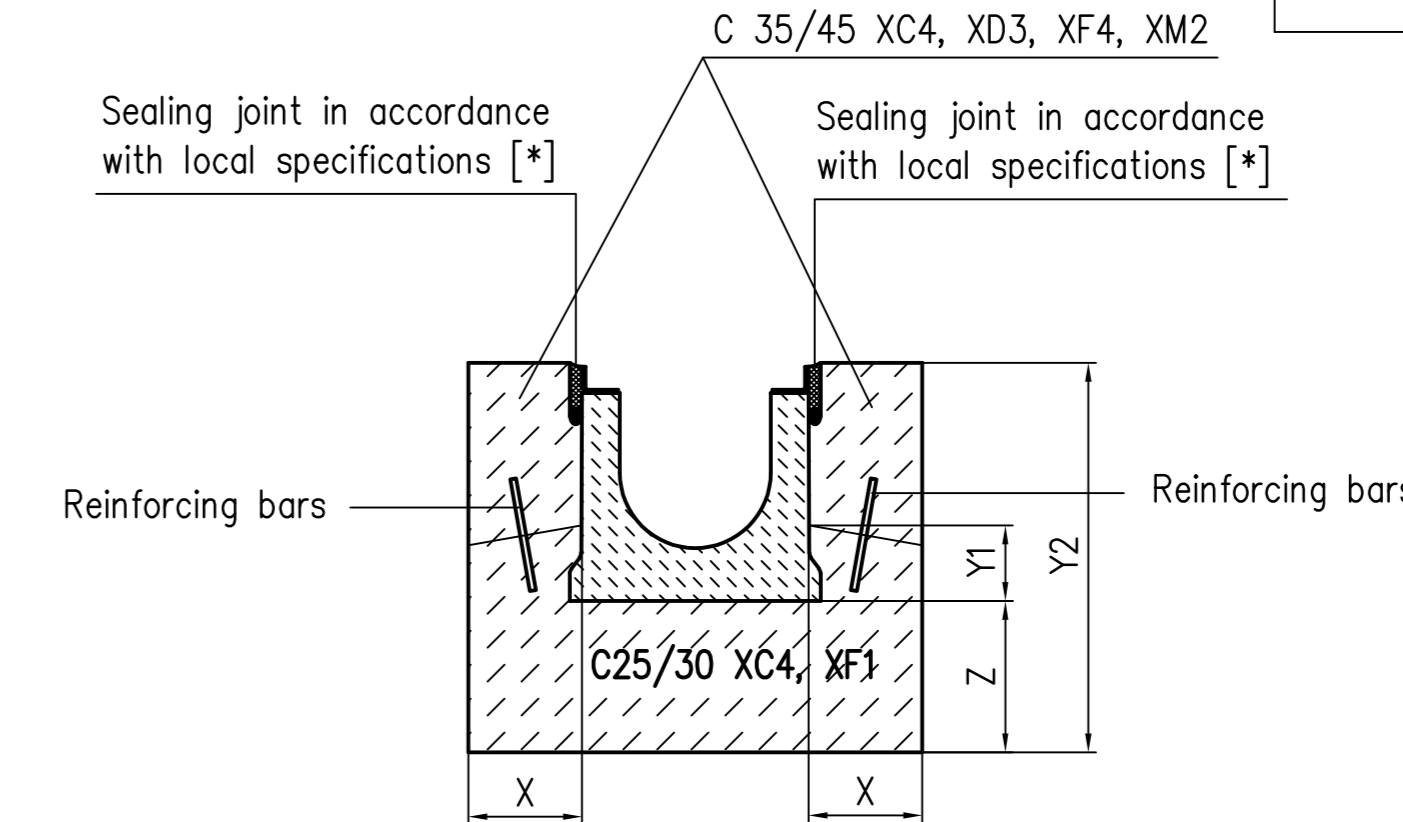
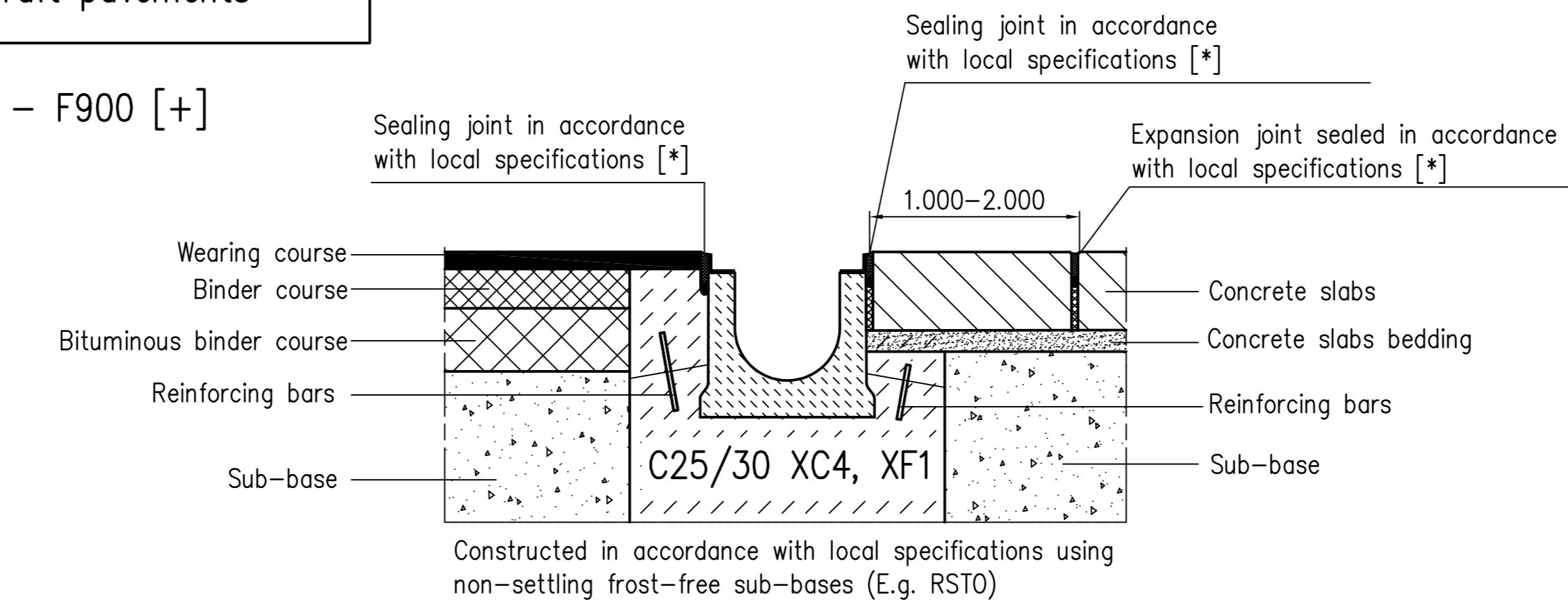

Presentation with BIRCOsir (s. channel cross section)

Type	Nominal width	Load class	X [mm]	Y1 [mm]	Y2 [mm]	Z [mm]
BIRCOlight	100	D 400 – E 600	≥150	≥100	channel height + 5mm	≥200
	150		≥150	≥100		≥200
	200		≥150	≥100		≥200
BIRCOlight triloc	100	D 400 – E 600	≥150	≥100		≥200
	150		≥150	≥100		≥200
	200		≥150	≥100		≥200
BIRCOsir	100	D 400 – F 900	≥150	≥100	≥200	
	150		≥150	≥100	≥200	
	200 AS		≥150	≥100	≥200	

BIRCOsir NW 100 / 150 / 200, Type I – load class A15 – C250

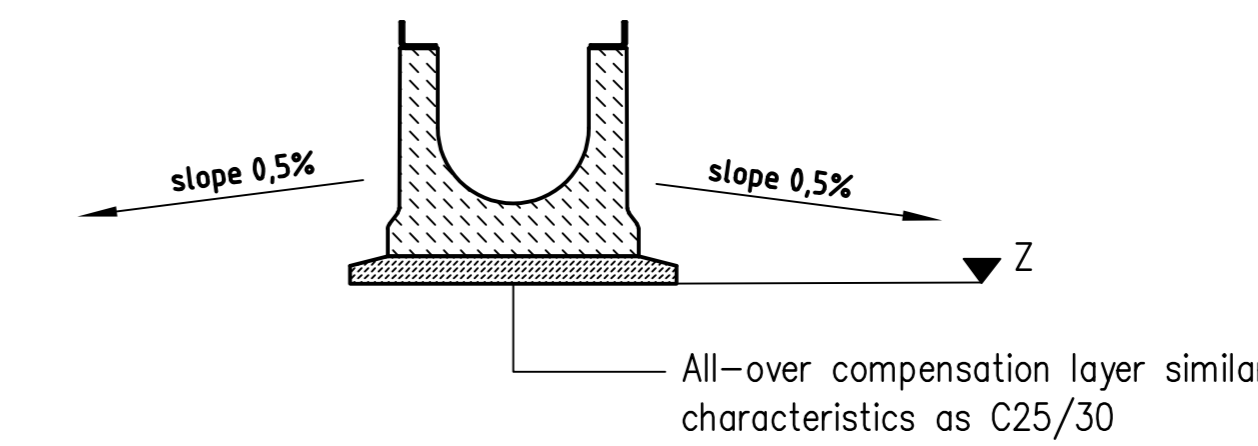
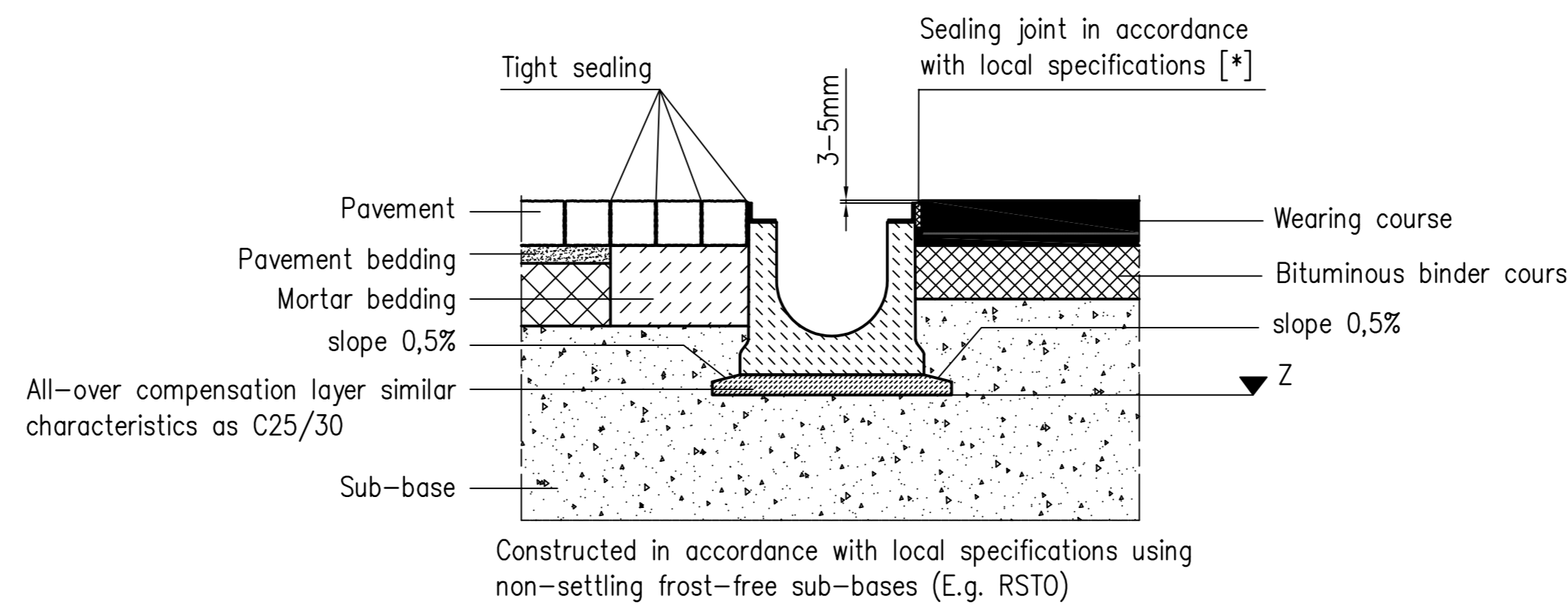

Z = The substructure must be designed long-lasting stable (settlement-free), in order to ensure the transfer of the expected loads without damage.

Presentation with BIRCOsir (s. channel cross section)

BIRCOsir NW 100 / 150 / 200, Typ I – Klasse D400

EXCEPT for load class E 600 and F 900 and for heavy-duty load areas exposed to frequent use For example Ports, Freight company premises, Industrial halls and trade fair centres

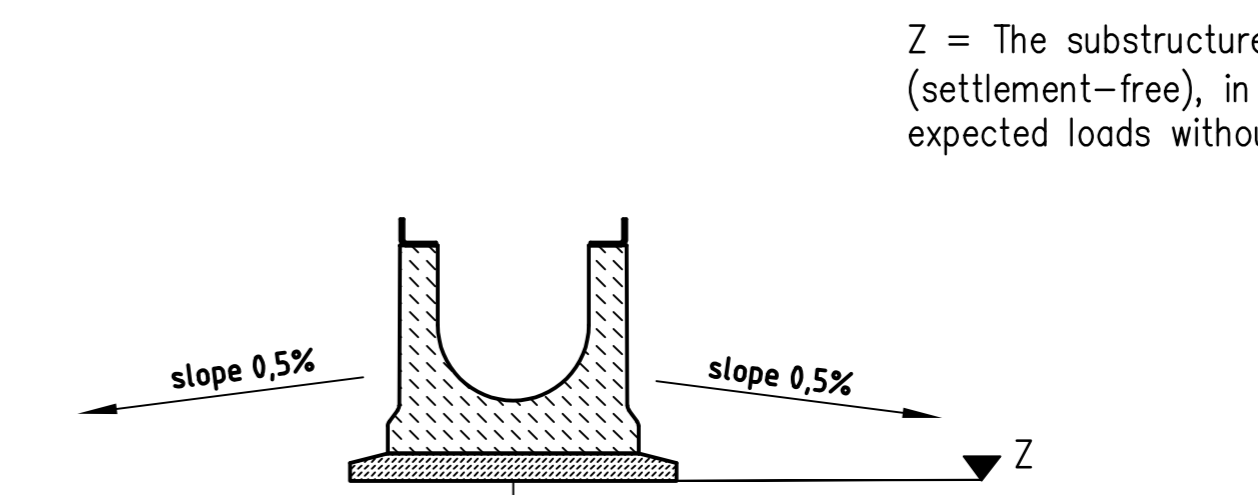
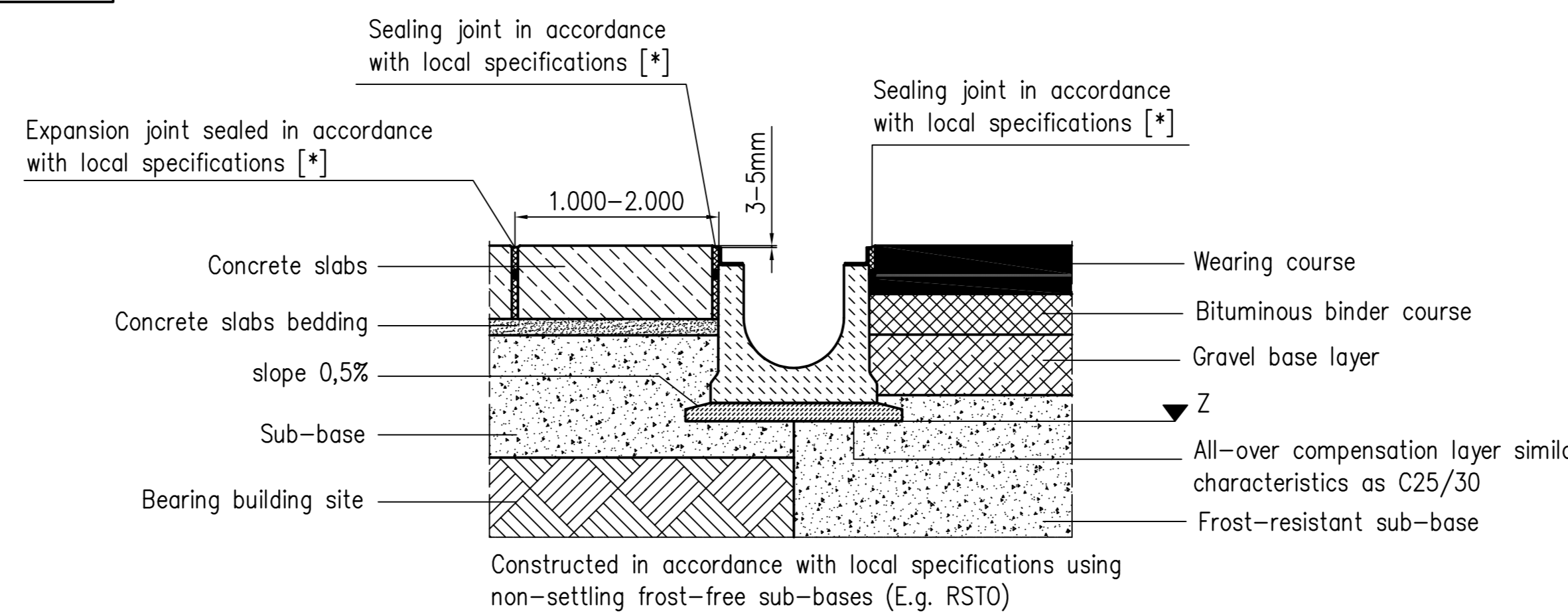

Z = The substructure must be designed long-lasting stable (settlement-free), in order to ensure the transfer of the expected loads without damage.

Presentation with BIRCOsir (s. channel cross section)

Copyright nach ISO 16016 / Copyright selon ISO 16016			
BIRCO GmbH Herrenpödel 142 76532 Baden-Baden			
gez. Datum	Nom. Name	Artikel-Nr. / N° d'article :	
dessein: 18.06.2024	99	Installation instructions Type M / Type I	
Maßstab / Echelle :	BIRCOplus – up to load class C 250		
1:10	BIRCOlight – up to load class E 600		
CAD: A. D.	BIRCOsir – up to load class F 900		
Zeichn. Nr. / N° plan	J:\ACAD\Einbau\EN\433\24550c_EN		